

INDUSTRIAL DIESEL ENGINE

KUBOTA SUPER MINI SERIES (2-cylinder)

Z482-E3B



RATED POWER

9.9 kW/3600 rpm

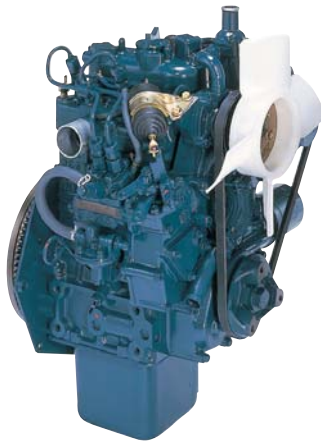

PERFORMANCE CURVE

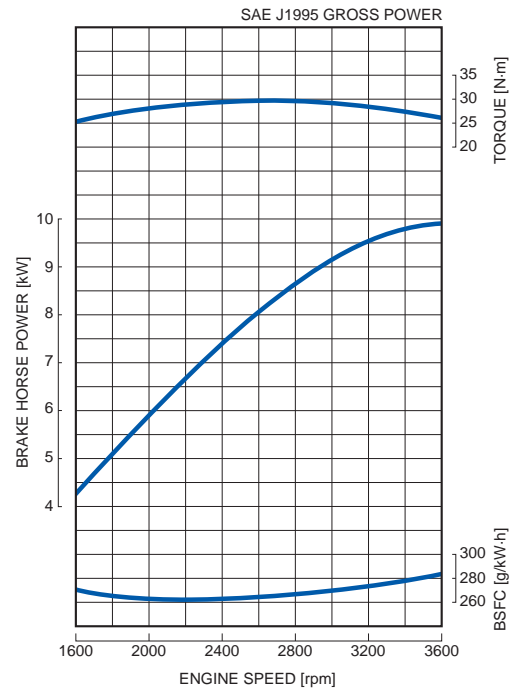

FEATURES with BENEFITS

Emissions

- Kubota Super Mini Series, the most compact multi-cylinder liquid cooled industrial diesel engines, complies with EPA Tier 4 emissions regulations. These are the most stringent emissions regulations in the world in this class.

Durable Power

- The Kubota Super Mini Series has been chosen as a power source for a variety of applications since it was first launched 25 years ago. It has become the benchmark in the compact diesel engine market.
- The Z482 engine offers a seamless transition from Tier 2 to Tier 4 by totally maintaining the same performance and physical characteristics of the previous Tier 2 engines.

Clean and Quiet Power

- Kubota's original E-TVCS (Three Vortex Combustion System) has been improved. The combustion chamber was optimized to achieve a 50% lower particulate matter (PM) level in such a small size range.

GENERAL SPECIFICATION

Model		Z482-E3B
Emission Regulation		Tier 4
Type		Vertical 2-cycle Liquid Cooled Diesel
Number of Cylinders		2
Bore	mm (in)	67 (2.64)
Stroke	mm (in)	68 (2.68)
Displacement	L (cu.in)	0.479 (29.23)
Combustion System		Indirect Injection
Intake System		Naturally Aspirated
Maximum Speed	rpm	3600
Output: SAE J1995 Gross Power (Industrial Use)	kW	9.9
	hp	13.3
	ps	13.5
Direction of Rotation		Counterclockwise Viewed on Flywheel
Oil Pan Capacity	L (gal)	2.5 (0.66)
Starter Capacity	V-kW	12-0.8
Alternator Capacity	V-A	12-12.5
Output: Stand-by (Generator Use)	kW	8.9
	hp	11.9
	ps	12.1
Output: Continuous (Generator Use)	kW	8.1
	hp	10.9
	ps	11.0
Length	mm (in)	360.6 (14.20)
Width	mm (in)	404.0 (15.91)
Height (1)	mm (in)	564.1 (22.21)
Height (2)	mm (in)	219.0 (8.62)
Dry Weight	kg (lb)	53.1 (117.1)

*Specification is subject to change without notice.

*Dry weight is according to Kubota's standard specification.

When specification varies, the weight will vary accordingly.

*SAE J1995 Gross Power: 1-hour rating based on engine without cooling fan, air cleaner and muffler, with alternator.

DIMENSIONS

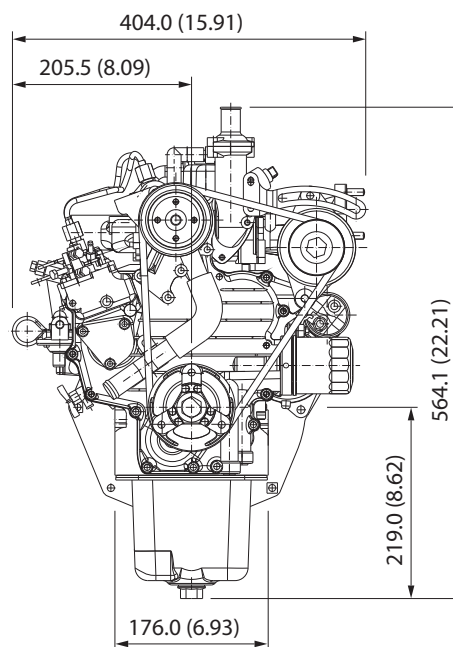
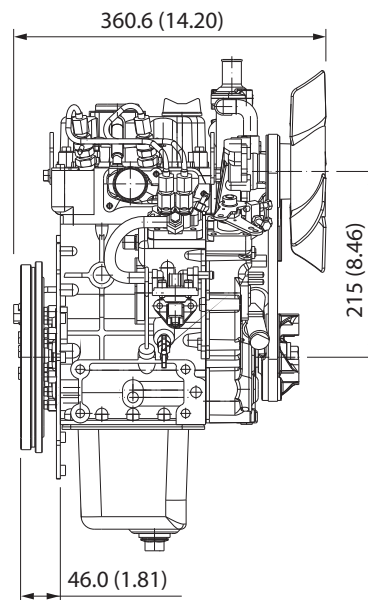

Kubota Corporation

2-47, Shikitsuhashi 1-chome, Naniwa-ku, Osaka, 556-8601 Japan
 Fax: +81 (0) 6 6648 /35 21
<http://www.engine.kubota.ne.jp>

Kubota (Deutschland) GmbH

Senefelder Str. 3-5

63110 Rodgau

Phone: +49 (0) 6106 / 873 - 113

Fax: +49 (0) 6106 / 873 - 196

eMail: motoren@kubota.de

homepage: www.kubota.de